

Castleton Model 8031

Clean and efficient with extra long burn times.

 **Efficiency**
77%
HHV

 **HeatLife™**
20
Hours

 **EPA Certified**
0.69
g/hr



Features

TruHybrid™ System

A 3-tube secondary combustion system with a fixed baffle ensure a clean burn before the catalyst performs the finishing touches.

Convenient Firebox

The square shape of the Castleton stove is perfect for loading the wood either side-to-side or front-to-back.

Easy to Use

Control the stove with one lever. Turn your stove to high and stoke a big fire. Turn it all the way down to keep a fire burning overnight.

Soapstone Wood Stoves

Castleton

Heritage

Mansfield



Dimensions

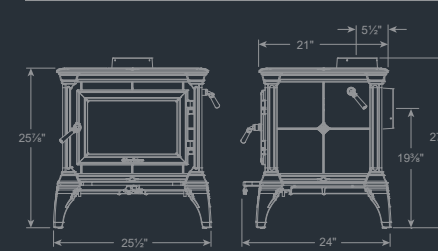

Clearances



Hearth Protection

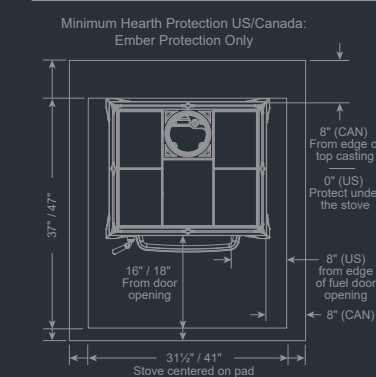

Finish Options

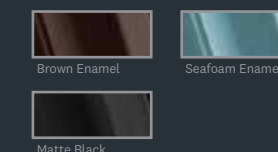

Specifications

HHV Efficiency	77%
HeatLife™ Burn Time*	20 hours
EPA Certified	0.69 g/hr
Heats up to.....	1,700 sq ft
Firebox Capacity	1.9 cu ft
BTU.....	Up to 45,000
Maximum Log Length	18"
Flue Exit & Diameter	Top or Rear - 6"
Weight	464 lbs

Accessories

Rear Heat Shield	90-68300
Convection Blower	90-57210
Outside Air Adapter	90-53300

Note: All information is for reference only. Refer to the owner's manual for full specification and installation details.

* Under the right conditions, you will be able to start a new fire with kindling up to the end of the product's HeatLife™.